

HYUNDAI
POWER PRODUCTS

PETROL TILLER
HMTC100-A

ORIGINAL INSTRUCTIONS

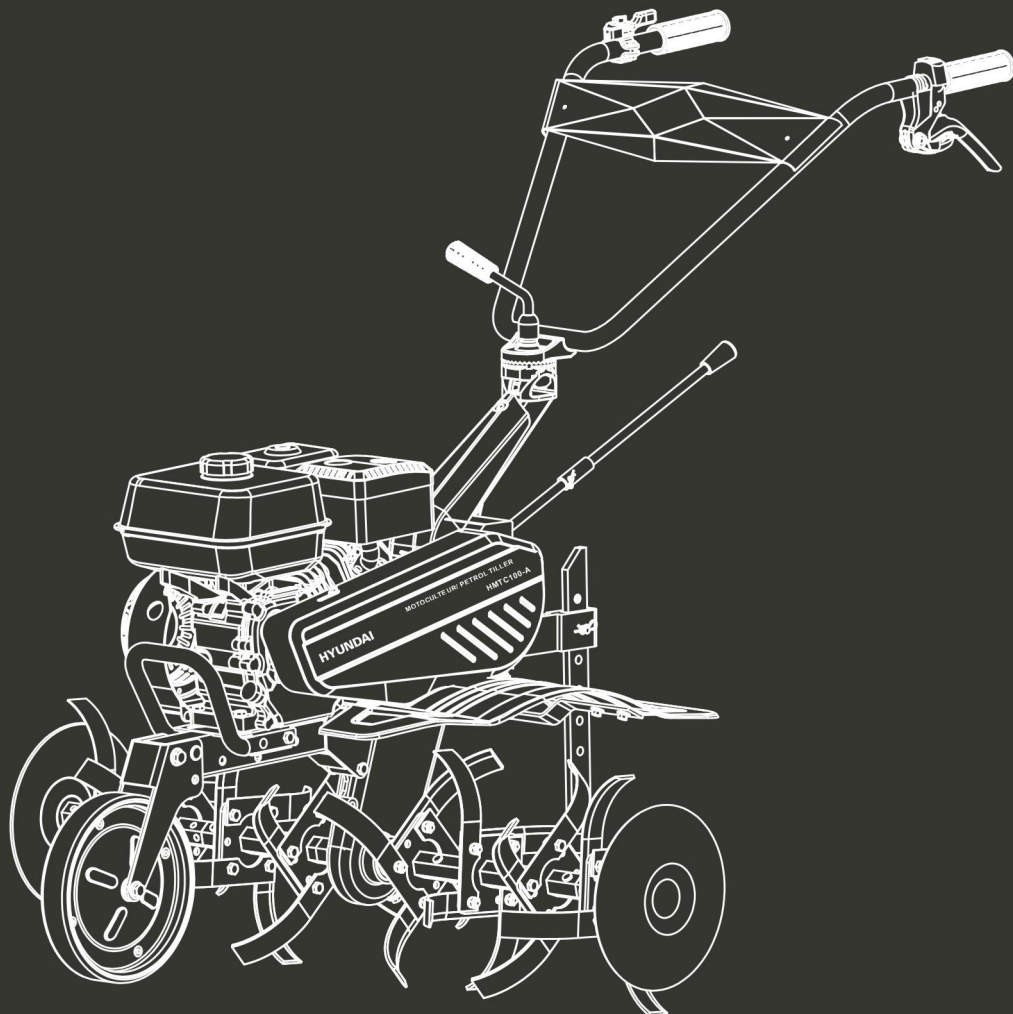

WARNING: Read thoroughly the instruction manual before using.

CONTENTS

1. SAFETY INSTRUCTIONS.....	3
2. DESCRIPTION.....	6
3. PRE-OPERATION CHECK.....	7
4. STRATING THE ENGINE.....	9
5. HIGH ALTITUDE OPERATION.....	11
6. OPERATION.....	11
7. TECHNICAL PARAMETER.....	15
8. MAINTENANCE.....	16
9. BREAKDOWN LIST.....	17
10. TRANSPORTING / STORAGE.....	22
11. TROUBLESHOOTING.....	23
12. DECLARATION OF CONFORMITY.....	24
13. WARRANTY.....	25
14. PRODUCT FAILURE.....	26
15. WARRANTY EXCLUSIONS.....	27

1. SAFETY INSTRUCTIONS

For your safety and safety of others please pay special attention to these precautions:

1) Training

- a) Read the instructions carefully. Be familiar with the controls and the proper use of the equipment;
- b) Never allow children or people unfamiliar with these instructions to use the machine. Local regulations can restrict the age of the operator;
- c) Never work while people, especially children, or pets are nearby;
- d) Keep in mind that the operator or user is responsible for accidents or hazards occurring to other people or their property.

2) Preparation

- a) While working, always wear substantial footwear and long trousers. Do not operate the equipment when barefoot or wearing open sandals;
- b) Thoroughly inspect the area where the equipment is to be used and remove all objects which can be thrown up by the machine;
- c) **WARNING** – Petrol is highly flammable:
 - Store fuel in containers specifically designed for this purpose;
 - Refuel outdoors only and do not smoke while refuelling;
 - Add fuel before starting the engine. Never remove the cap of the fuel tank or add petrol while the engine is running or when the engine is hot;
 - If petrol is spilled, do not attempt to start the engine but move the machine away from the area of spillage and avoid creating any source of ignition until petrol vapours have dissipated;
 - Replace all fuel tank and container caps securely;
- d) Replace faulty silencers;
- e) Before using, always visually inspect to see that the tools are not worn out or damaged. Replace worn out or damaged elements and bolts in sets to preserve balance.

3) Operation

- a) Do not operate the engine in a confined space where dangerous carbon monoxide fumes can collect;
- b) Work only in daylight or in good artificial light;
- c) Always be sure of your footing on slopes;
- d) Walk, never run with the machine;
- e) For wheeled rotary machines, work across the slopes, never up and down;
- f) Exercise extreme caution when changing direction on slopes;
- g) Do not work on excessively steep slopes;
- h) Use extreme caution when reversing or pulling the machine towards you;
- i) Do not change the engine governor settings or overspeed the engine;
- j) Start the engine carefully according to manufacturer instructions and with feet well away from the tool(s);
- k) Do not put your hands or feet near or under rotating parts;
- l) Never pick up or carry a machine while the engine is running;
- m) Stop the engine:
 - Whenever you leave the machine;
 - Before refuelling;

n) Reduce the throttle setting during engine shut down and, if the engine is provided with a shut-off valve, turn the fuel off at the conclusion of working;

4) Maintenance and storage

- a) Keep all nuts, bolts and screws tight to ensure the equipment is in safe working condition;
- b) Never store the equipment with petrol in the tank inside a building where fumes can reach an open flame or spark;
- c) Allow the engine to cool before storing in any enclosure;
- d) To reduce the fire hazard, keep the engine, silencer, battery compartment and petrol storage area free of vegetative material and excessive grease;
- e) Replace worn or damaged parts for safety;
- f) If the fuel tank has to be drained, this shall be done outdoors.

Thrown Object Hazard

Objects hit by the rotating tines can be thrown from the tiller with great force and may cause severe injury.

- 1) Before tilling, clear the tilling area of sticks, large stones, wire, glass etc.
- 2) Pieces thrown from worn or damaged-tines can cause serious injury. Always inspect the tines before using the tiller.

Fire and Burn Hazard

Gasoline is extremely flammable and gasoline vapor can explode.

Use extreme care when handling gasoline. Keep gasoline out of reach of children.

- 1) Refuel in a well-ventilated area with the engine stopped.
- 2) Allow the engine to cool before refueling. Fuel vapor or spilled fuel may be ignited.
- 3) The engine and exhaust system becomes very hot during operation and remains hot after stopping. Touching them can cause burn injuries or some materials burn.
- 4) Avoid touching a hot engine or exhaust system.
- 5) Allow the engine to cool before performing maintenance or storing the tiller indoors.

Carbon Monoxide Poisoning Hazard













Exhaust contains poisonous carbon monoxide a colorless and odorless gas. Breathing exhaust can cause loss of consciousness and may lead to death.

Operation on Slope

- 1) When tilling on slopes, keep the fuel tank with less than half oil to minimize fuel spillage.
- 2) When the tiller walks across the slope, put your effort evenly while walking up and down the slope.
- 3) Be very careful when changing the direction of the tiller on a slope.
- 4) Do not use the tiller on a slope of more than 10°.
- 5) The maximum safe grade angle shown is for reference only and the details should depend on the type of the tool. Before starting the engine, check that the tiller is not damaged and in good condition. For your safety or safety of others, pay special attention when using the tiller up or down hill.

5) WARNING SYMBOL

	Attention!
---	------------

	Caution: fire risk!
	The part is extremely hot! Do not touch!
 	Read the instruction manual before use
 	Caution: Do not put your hands in belt when it running.
 	Caution: rotating working tool!
	Keep away from the machine.
 	Warning: Exhaust emissions are harmful to health of body.
	Add engine oil.

- That the machine shall always be used in accordance with these manufacturer's instructions the instruction handbook
- The engine shall be stopped when carrying out maintenance and cleaning operations, when changing tools and when being transported by means other than under its own power;
- Some hazards can be met when working on slopes; work slowly by holding firmly the tool. Do not transport the tool on slopes. The hazards can rise when working on difficult soil (stony, hard, etc.). there is a risk to hit some objects, sliding, lose control for the machine which will gives damages. Always inspect the working area before working, and always watch what you are doing.
- The adjustable part of the protective device shall be adjusted to the working depth of the tool so that only that part of the working tool that cuts into the soil remains uncovered. This does not apply to motor hoes.
- The machine should only be operated by suitably trained persons.
- During the operation of the machine safety shoes should be worn.
- Always start up the machine under normal conditions

6) Intended use

This device is to be used only as an electric hoe for aerating lawns and grassy areas in private home gardens and pleasure gardens. It is not intended for use in public spaces, parks, sports fields, agriculture or forestry. Use of this device for any other purpose is considered incorrect and unapproved. The manufacturer will not be responsible for any damage or injury resulting from such use. The user is fully responsible for all related risks.

2. DESCRIPTION

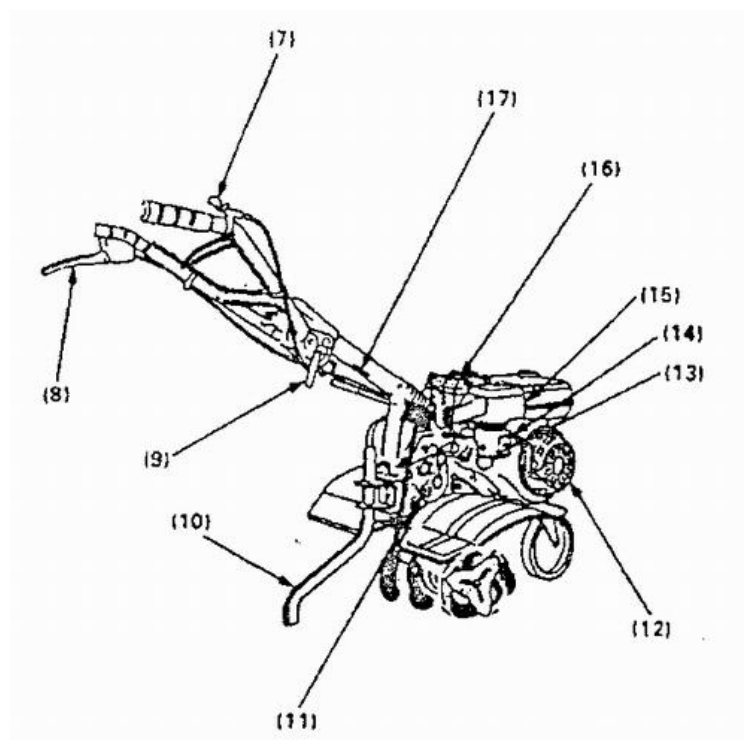
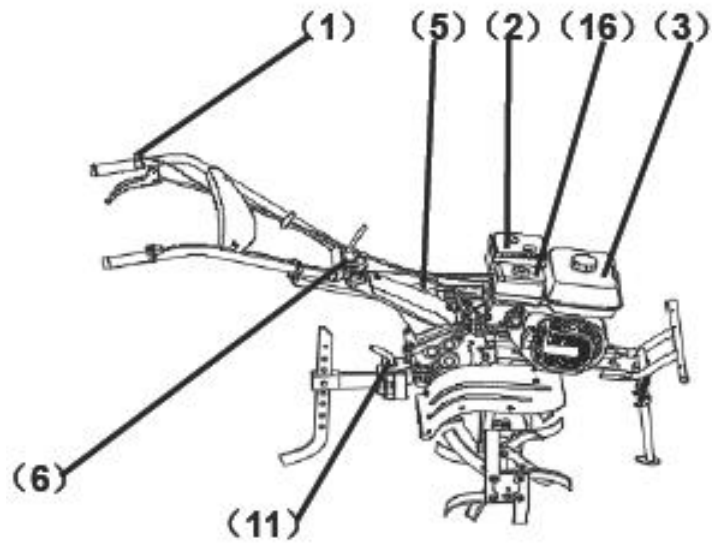
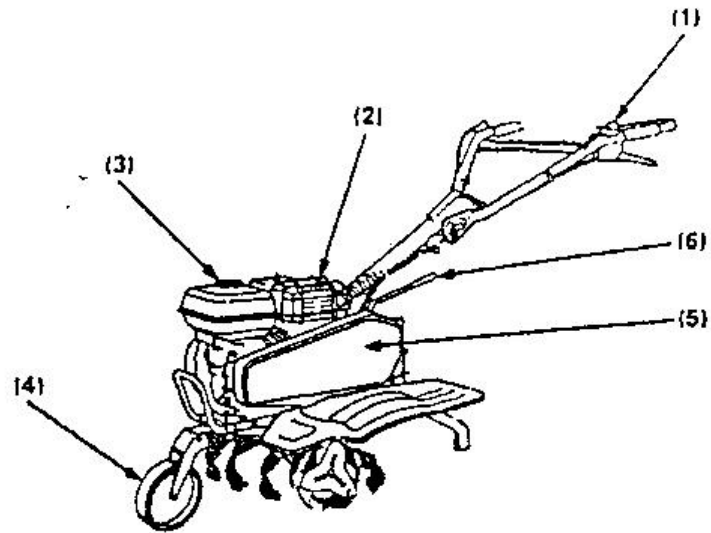

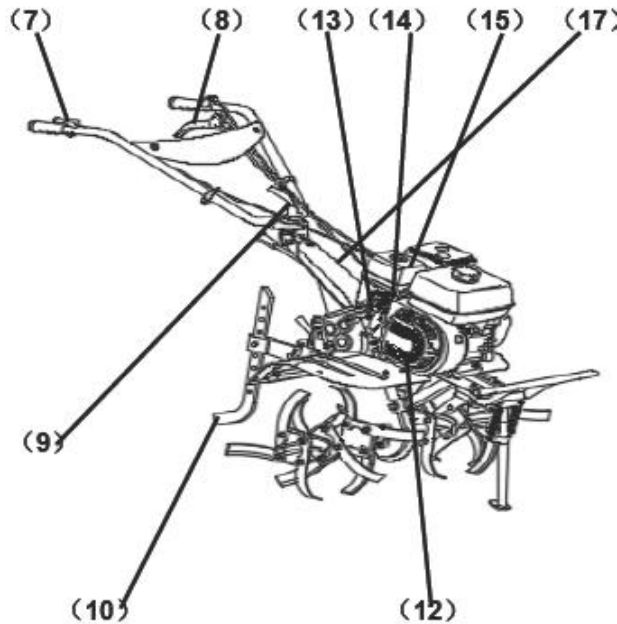

- | | |
|--------------------------|------------------------------|
| (1) ENGINE SWITCH | (10) DRAG BAR |
| (2) MUFFLER | (11) TRANSMISSION OIL FILLER |
| (3) FUEL TANK | (12) RECOIL STARTER |
| (4) FRONT WHEEL | (13) FUEL VALVE |
| (5) BELT COVER | (14) CHOKE LEVER |
| (6) SHIFT LEVER | (15) AIR CLEANER |
| (7) THROTTLE CONTROL | (16) SPARK PLUG |
| (8) CLUTCH | (17) FRAME |
| (9) HANDLE HEIGHT ADJUST | |

3. PRE-OPERATION CHECK

1) Engine oil

CAUTION: Running the engine with low oil level will cause serious engine damage.

1. Remove the oil filler cap and wipe the dipstick clean.
2. Insert the dipstick into the oil filler neck but do not screw it in.
3. If the level is low, fill the recommended oil to the top of the oil filler neck.

Use high-detergent, premium quality 4-stroke engine oil, certified to meet or exceed U.S. automobile manufacturer's requirement for API Service Classification SG.SF

CAUTION: Using non-detergent oil or 2-stroke engine oil could shorten the engine's service life.

SAE 10W-30 is recommended for general all-temperature use. Other viscosities shown in the following chart might be used when at the average temperature in your area is within the indicated range.

- (1) OIL FILLER HOLE
- (2) UPPER LEVEL
- (3) LOWER LEVEL

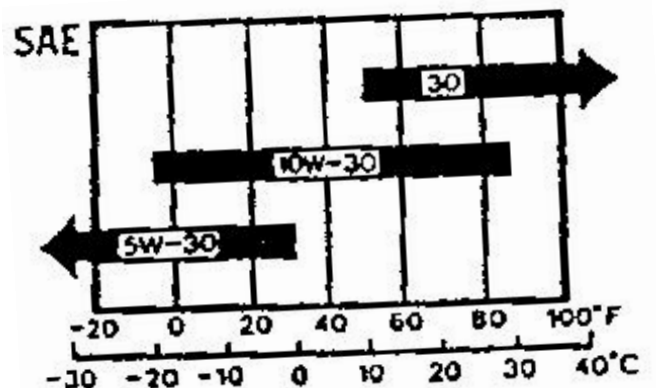

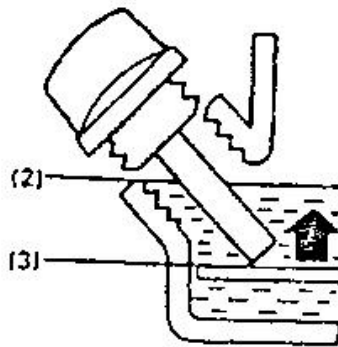
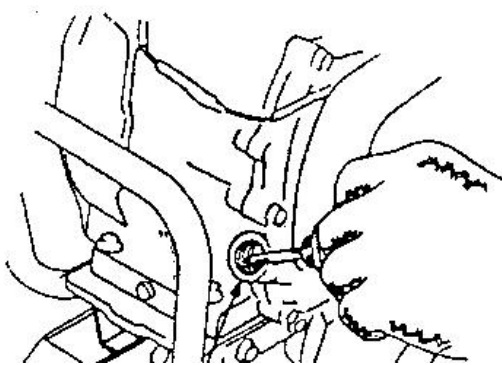

2) TRANSMISSION GEAR OIL

Place the tiller on a level surface and remove the oil filler cap.
The oil should be level with the lower edge of the oil filler hole.
Add high quality engine oil if the level is low.

(1) OIL FILLER HOLE

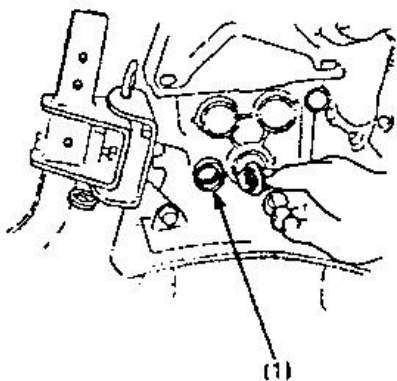

3) AIR CLEANER

Check cleaner for dirt or obstruction of elements

(1) ELEMENTS

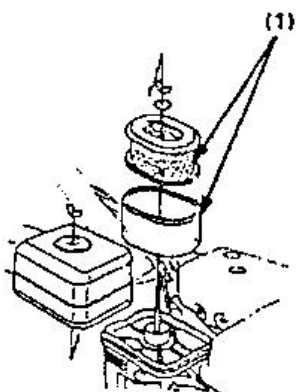

4) FUEL

Use automotive gasoline (Unleaded or low leaded is preferred to minimize combustion chamber deposits.)

FOR NEW SOUTH WALES ONLY:

Use unleaded fuel only:

Never use an oil/gasoline mixture or dirty gasoline. Avoid getting dirt, dust or water in the fuel tank.

CAUTION: Do not fill over the red level line.

⚠ WARNING

- Gasoline is extremely flammable and is explosive under certain conditions.
- Refuel in a well-ventilated area with the engine stopped. Do not smoke or allow flames or spark in the area where the engine is refueled or where gasoline is stored.
- Do not overfill the fuel tank (there should be no fuel in the filler neck). After refueling, make sure the tank cap is closed properly and securely.
- Be careful not to spill fuel when refueling. Spilled fuel or fuel vapor may ignite. If any fuel is spilled, make sure the area is dry before starting the engine.
- Avoid repeated or prolonged contact with skin or breathing of vapor.

Fuel tank capacity: 3.6L

(1) RED LEVEL LINE

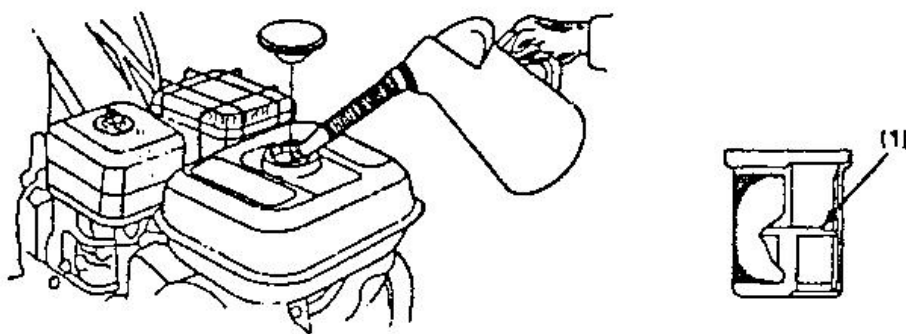

Gasoline containing alcohol

If you decide to use a gasoline containing alcohol (gasohol), be sure it's octane rating is at least as high as that recommended for Motor Hoes. There are two types of "gasohol": one containing ethanol and the other containing methanol! Do not use gasohol that contains more than 10% ethanol! Do not use gasoline containing methanol (methyl or wood alcohol) that does not also contain inhibitors for methanol corrosion! Never use gasoline containing more than 5% methanol, even if it has corrosion inhibitors.

NOTE:

- Fuel system damage or engine performance problems resulting from the use of fuels that contain alcohol are not covered under the warranty. Motor Hoes can not endorse the use of fuels containing methanol since evidence of their suitability is as yet incomplete.
- Before buying fuel from an unfamiliar station try to find out if the fuel contains alcohol, if it does, confirm the type and percentage of alcohol used. If you notice any undesirable operating symptoms while using a gasoline that contains alcohol or one that you think contains alcohol switch to a gasoline that you know does not contain alcohol.

5) Tool and Attachments

To install a tool or attachment on the tiller follow the instructions furnished with the tool or attachment. Ask your dealer for advice if you encounter any problem or difficulty in installing a tool or attachment.

4. STARTING THE ENGINE

CAUTION: Be sure the clutch is disengaged and the shift lever is in the neutral position to prevent sudden uncontrolled movement when the engine starts. The clutch is engaged by pulling in the clutch lever and disengaged by releasing the lever.

1). Turn the fuel valve to ON. Check up tightness of drain knob.

- (1) FUEL VALVE
- (2) ON
- (3) DRAIN KNOB

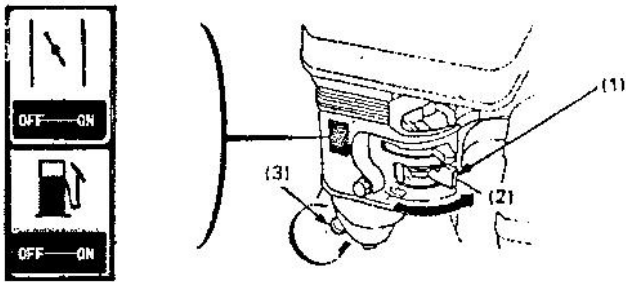

2). Close the choke lever.

NOTE: Do not use the choke if the engine is warm or the air temperature is high.

- (1) CHOKE LEVER
- (2) CLOSE

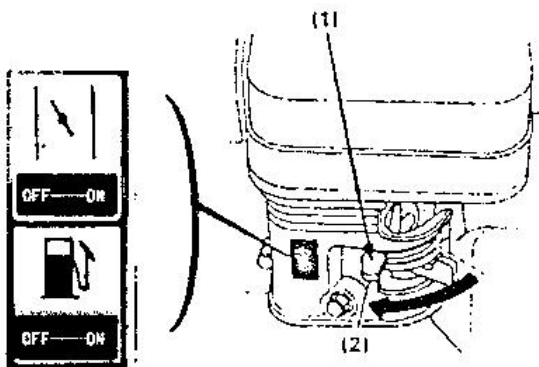

3). Turn the engine switch to ON

- (1) ON
- (2) ENGINE SWITCH

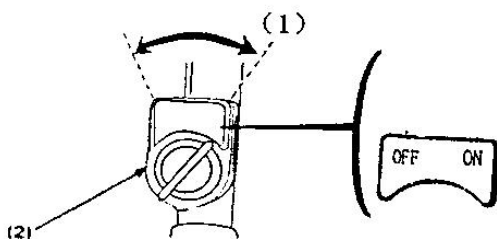

4). Move the throttle lever slightly to the right.

- (1) THROTTLE LEVER

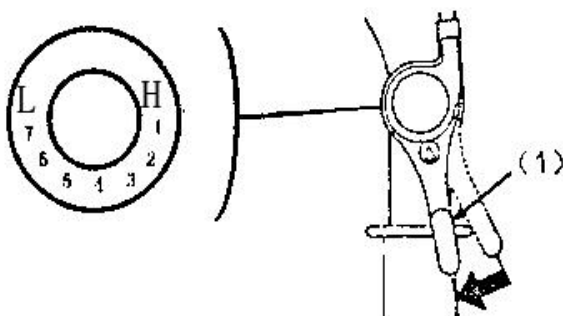

5). Pull the starter grip lightly until resistance is felt then pull briskly.

CAUTION: Do not allow the starter grip to snap back against the engine. Return it gently to prevent damage to the starter.

(1) STARTER GRIP

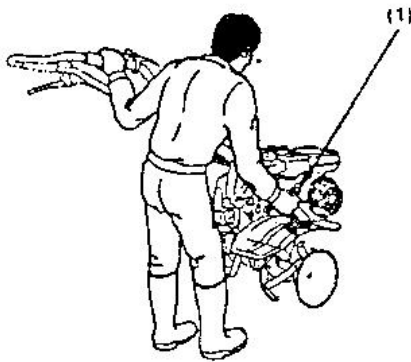

6). As the engine warms up. Gradually open the choke.

(1) CHOKE LEVER

(2) OPEN

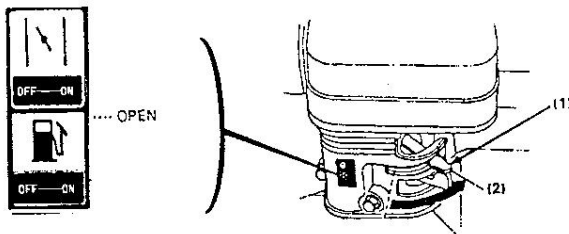

5. HIGH ALTITUDE OPERATION

At high altitude the standard carburetor air-fuel mixture will be excessively rich. Performance and fuel consumption will increase.

High altitude performance can be improved by installing a smaller diameter main fuel jet in the carburetor and readjusting the pilot screw. If you always operate the tiller at altitudes higher than 1.830m (6.000feet) above sea level ask your authorized Motor Hoes dealer to perform these carburetor modifications.

Even with suitable carburetor jetting, engine horsepower will decrease approximately 3-5% for each 305m (1.000foot) increase in altitude.

The affect of altitude on the horsepower will be greater than this if no carburetor modification is made.

CARTION: Operation of the tiller at an altitude lower than the carburetor is jetted for may result in reduced performance overheating and serious engine damage caused by an excessively lean air / fuel mixture

6. OPERATION

1). Handlebar height adjustment

CAUTION: Before adjusting the handlebar place the tiller on firm level ground to prevent the handle from collapsing accidentally.

To adjust the handlebar height, loosen the adjuster select the appropriate holes and tighten the adjuster.

(1) ADJUSTER

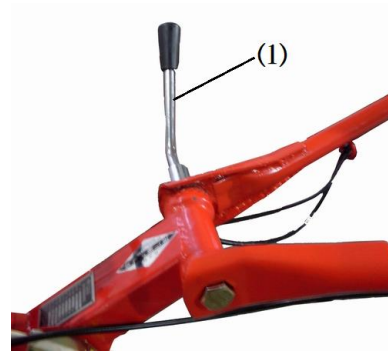
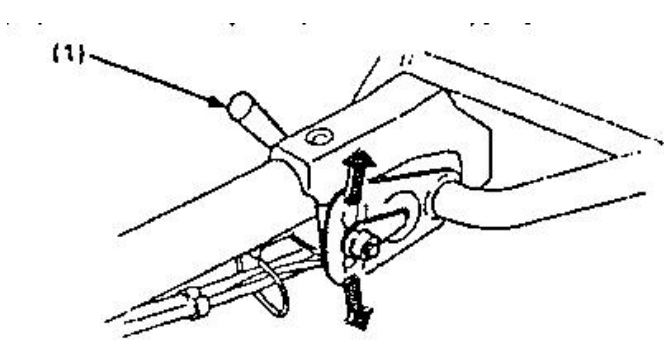

2). Tilling depth adjustment

Install the hitch attachment in the hitch box with a hitch pin.

The tilling depth adjustment can be made as follows:

Remove the pin and lock pin loosen the bolt securing the drag bar and sliding the drag bar up or down as necessary.

- (1) HITCH BOX
- (2) HITCH PIN
- (3) LOCK PIN
- (4) DRAG BAR
- (5) PIN

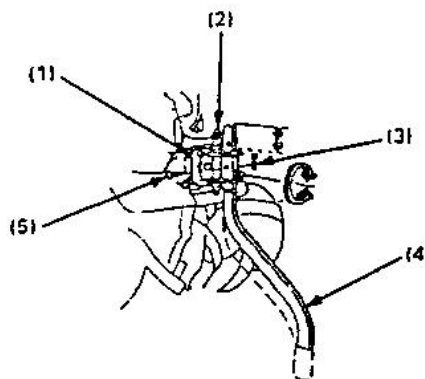

3). Clutch operation

The clutch engages and disengages the power from the engine to the transmission.

When the clutch lever is squeezed the clutch is engaged and power is transmitted. Squeeze the lever. The tool will be rotated.

When the lever is released the clutch is disengaged and power is not transmitted. Release the clutch lever. The tool will be stopped.

CAUTION: Reduce engine rpm before operating main clutch.

- (1) CLUTCH LEVER
- (2) ENGAGED
- (3) DISENGAGED

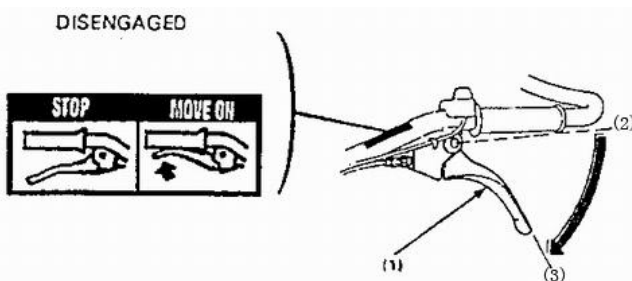

4). Gear selection

The transmission can be shifted into the 2nd forward gear.

The shift lever should be operated in accordance with the attached gear shifting plate.

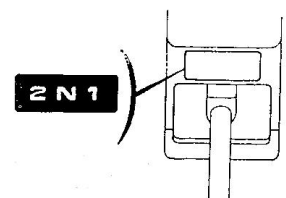

Gear shifting:

- (1). Return the throttle lever to the extreme right.
- (2). Release the clutch lever to disengage the clutch
- (3). Move the shift lever to the desired gear position

NOTE: If the shift lever will not engage the desired gear squeeze the clutch lever and move the motor hoes slightly to reposition the gears.

- (4). Squeeze the clutch lever to engage the clutch.

5). Choose the gear

The motor hoe has three gears to choose:

Gear Converted:

- (1) Pulling the throttle switch to the right
- (2) Unloosen the clutch handle and let the clutch separate.
- (3) Moving the gear shifting arm to your required gear
- (4) Gripping the clutch handle, the engine will work on the converted gear

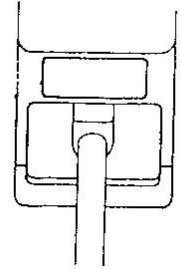

Gear Shifting
Reverse (-1), Forward (1), Neutral (0), Forward (2)

6). Use of a hitch box

Install the hitch attachment in the hitch box with a hitch pin.

- (1) HITCH BOX
- (2) HITCH PIN

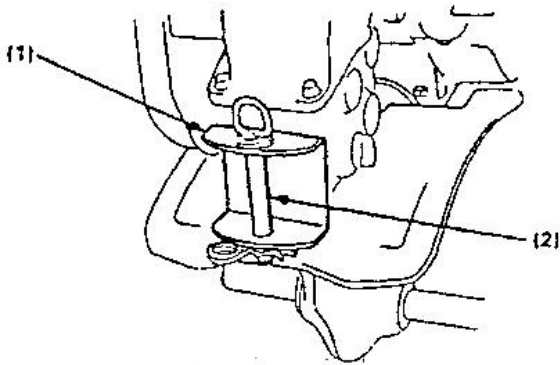

7). Front wheel

Move the motor hoes on road by the front wheel; lift the handlebars up the ground the front wheel. When the tiller is used in the field, move the wheel up by replacing the lock pin.

- (1) When used in the field
- (2) LOCK PIN
- (3) When moved on road

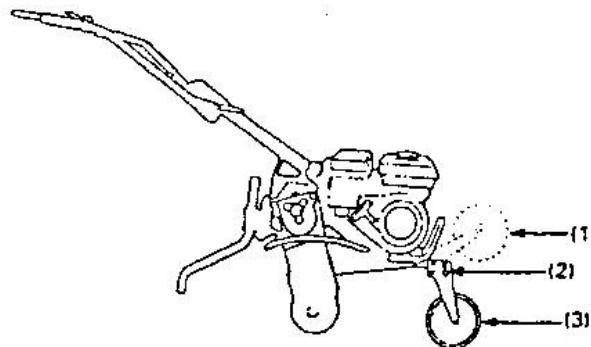

8). Handling tips

Adjust the handlebar height to a comfortable position (waist height for normal tilling). Should the machine jerk forward while tilling. Press down the handlebars. If the machine will not move forward, move the handlebars from side to side.

Turn: The proper method of negotiating a turn during a tilling operation is to lower the handlebars to bring the gravity centre toward the rear and then make the turn this will permit a turn to be made with relative ease.

9). Normal operating angle

Lower the handle slightly so the front of the machine is raised about 6-8°

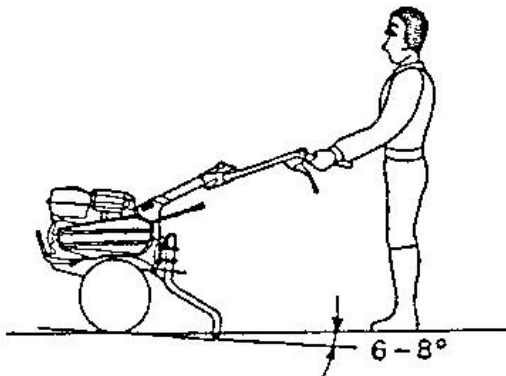

To get the maximum advantage from the tiller, try to hold the machine at the angle shown while you are tilling the ground

CAUTION:

- Do not use the tiller with a rotor whose diameter is in excess of 300mm.
- Operating the tiller on grades could cause the tiller to trip over.
- Allowing any one to operate this motor hoes without proper instruction may result in injury.
- Wear sturdy full coverage footgear. Operating this tiller with bare feet or with open toe shoes or sandals increase your risk of injury.
- Do not use the tiller in the night.
- Be sure to use two people to transport the tiller from one place to another without using a carrier.
- When the rotor is clogged with mud, pebble etc. immediately stop the engine and clean the rotor in a safe place. Be sure to wear heavy gloves when cleaning the rotor.

To prevent damage, check the tiller for any signs of damage or other faults each time the tiller is used after it has been operated last.

In an emergency:

Turn the engine switch to "OFF"

- (1) OFF
- (2) ENGINE SWITCH

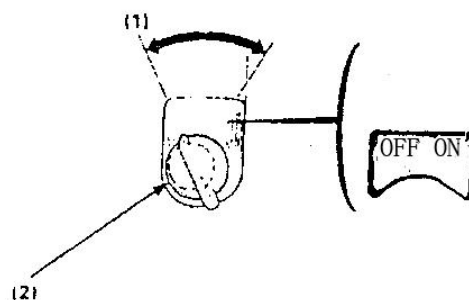

In normal use:

Release the clutch lever to DISENGAGED position and shift lever is in neutral position.

- (1) CLUTCH LEVER
- (2) DISENGAGED

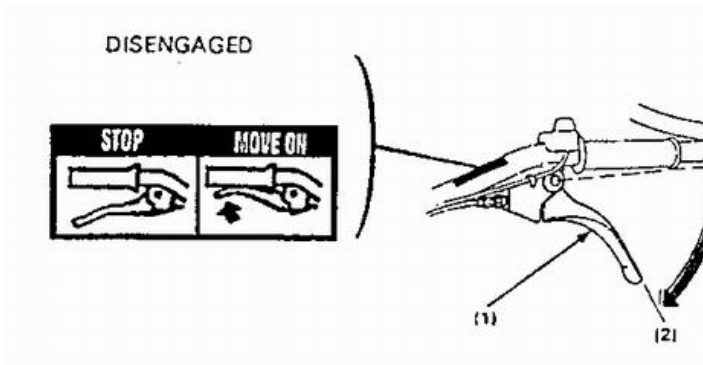

- 1). Move the throttle lever fully to the right.
- (1) THROTTLE LEVER

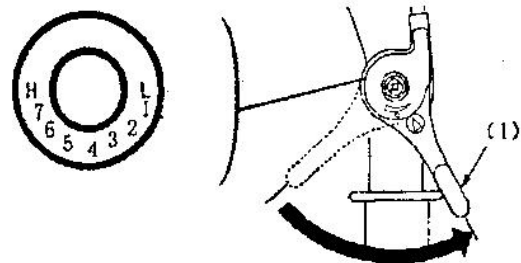

- 2). Turn the engine switch to OFF
- (1) OFF
- (2) ENGINE SWITCH

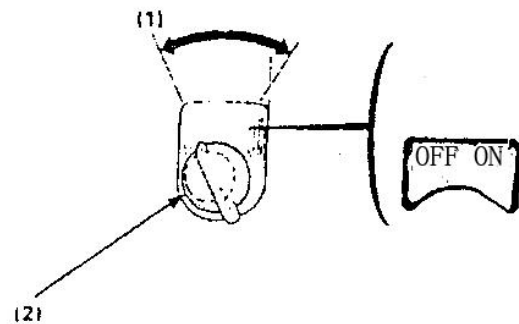

- 3). Turn the fuel valve to OFF
- (1) FULE VALVE
- (2) OFF

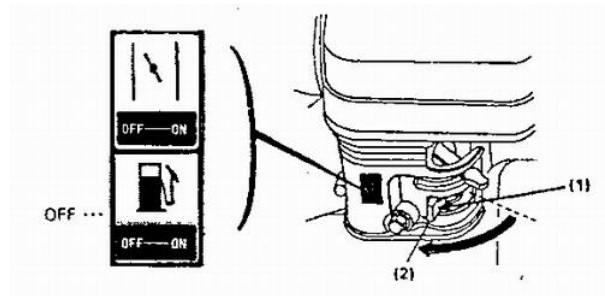

7. TECHNICAL PARAMETER

ITEM		HMTC100-A
TILLER	Dimension packed(L x W x H) (mm)	830x460x690
	N.W/G.W(kg)	85/94
	Transmission System	Belt + Chain
	Tilling (mm)	1000
	Guarantee sound power level	98 dB(A)
	Sound power level	Left: 78,9 dB(A) Right: 80dB(A)
	Sound pressure level	94.1 dB(A).
	Vibration	Left: 6,14m/s ² K=1,5m/s ² Right: 5,48 m/s ² K=1,5m/s ²

ENGINE	Engine Model	H170F
	Type	4-stroke, 1-cylinder, OHV, forced air cooled
	Displacement	212cm ³
	Power	4 kW
	Speed	3600/min
	Oil capacity	0.6L
	Fuel tank capacity	3.6L

8. MAINTENANCE

The purpose of the maintenance schedule is to keep the tiller in the best operating condition. Inspect or service as scheduled in the table below.

WARNING

Shut off the engine before performing any maintenance. If the engine must be run, make sure the area is well ventilated. The exhaust contains poisonous carbon monoxide gas.

CAUTION: Use only genuine 750 parts or their equivalent. The use of replacement parts which are not of equivalent quality may damage the engine.

Maintenance schedule

ITEM		REGULAR SERVICE PERIOD PERFORM AT EVERY INDICATED MONTH OR OPERATING HOUR INTERVAL, WHICHEVER OCCURS FIRST				
		Daily	First Month Of 20 Hrs.	Every 3 months Of 50Hrs.	Every 6 months of 100 Hrs.	Every year of 300 Hrs.
Engine oil	Check level	o				
	Change		o		o	
Air Cleaner Element	Check	o				
	Clean			O(1)		
Fuel Strainer Cup	Clean				o	
Spark Plug	Clean-readjust				o	
Transmission Gear Oil	Check level	o				
Tappet Clearance	Check –Readjust					O(2)
Fuel Tank and Strainer	Clean					O(2)
Clutch Cable	Adjust		o		o	
Throttle Cable	Adjust					o
Belt Tension	Adjust		o		o	
Fuel Line	Check	Every 2 Years (2) (Replace if necessary)				

9. BREAKDOWN LIST

A. Gasoline engine

(1) Hard to start machine or fail to start

Breakdown phenomenon	Cause	Solution	
no spark at plug	spark plug	carbon deposition of spark plug	clear away carbon
		excessive or too small clearance of spark plug	adjust clearance to 0.7~0.8mm
		Insulation damage of spark plug	replace spark plug
	Others	breakdown of ignitor	replace ignitor
		weak magnetic force of flywheel	replace flywheel
Sparking at plug	good compression	suck excessive fuel into cylinder	take off spark plug and dry it and put it on
		poor quality of fuel with water and dirt	replace fuel
	Loosen oil drain screw at the bottom of Carburetor .No oil shedding.	needle valve block	clean or replace carburetor
	normal oil supply but poor compression	piston ring abrasion, loose spark plug	replace
		Air leak of cylinder head	screw tight
		wrong air valve clearance or timing	clean, readjust and reassemble
	normal ignition and oil supply	poor contact of high voltage cable and spark plug	replace and connect
		Failure of stop switch , short circuit	clean
		breakdown of oil alert	replace

(2) Abnormal conditions in the movement

Breakdown phenomenon	Cause	Solution
Insufficient power, Low rotation	damper closed, poor ventilation of muffler	open damper, replace muffler
	moving parts abrasion	check, replace
	speed adjustment mechanism failed to reach the best equilibrium	adjust speed adjustment mechanism
	low ignition power	replace ignitor or flywheel
	excessive clearance of air valve	regulate to the required scope
	carbon deposition	Clear away carbon
excessive fluctuation of speed	speed adjustment mechanism failed to reach the most optimized combination	adjust speed adjustment mechanism
	wrong carburetor	replace carburetor
	wrong space of spark plug	adjust clearance

excessively high speed of rotation	speed adjusting handle failed to press adjust cap tightly or Speed adjust cap lost	Readjust or install speed adjustment cap
abnormal sound	wrong clearance of air valve	adjust clearance of air valve
	cam gear injured	replace camshaft
oil leaking of carburetor	needle valve and oil dirt attached	lightly tap carburetor or clean it.
	O-ring deformation	replace

B. Tiller

Abnormalities	Common Causes	Measures to be taken
Strange noises	Stuck blade	Turn off the tiller until the engine is completely stopped.
	Leakage of lubricating oil	Fix it in the repair shop
	Loose bolts, nuts and other components	Tighten all the components, if strange noises remain, please contact repair shop
Strong vibration	Damage or wear of the blade	Change blade or fix it in repair shop
	Excessive tillage depth	Adjust the tillage depth
Poor tillage effect	Shallow tillage	Adjust the tillage depth
	Blunt or worn blade	Change blade or fix it in repair shop

NOTE (1): Service more frequently when used in dusty areas

(2): These items should be serviced by an authorized 750 dealer, unless the owner has the proper tools and is mechanically proficient. See the 750 Shop Manual.

1). Changing oil

Drain the oil while the engine is still warm to assure rapid and complete draining

(1) Remove the oil filler cap, and drain the oil

(2) Refill with the recommended oil (see page 9) and check the level

Oil capacity: 0.6 L

(1) DRAIN PLUG

(2) OIL FILLER CAP

(3) UPPER LEVEL

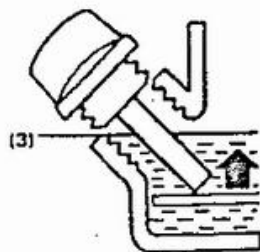
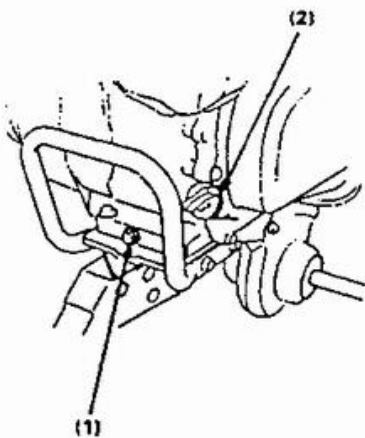

Wash your hands with soap and water after handling used oil.

NOTE: Please dispose of used motor oil in a manner that is compatible with the environment. We suggest you take it in a sealed container to your local service for reclamation. Do not throw it in the trash or pour it on the ground.

2). Air cleaner service

A dirty air cleaner will restrict air flow to the carburetor. To prevent malfunction, service the air cleaner regularly. Service more frequently when operating the engine in extremely dusty areas.

⚠ WARNING

Never use gasoline or low flash point solvents for cleaning the air cleaner element. A fire or explosion could result in.

CAUTION: Never run the engine without the air cleaner. Rapid engine wear will be the result.

(1). Remove the wing nut and the air cleaner cover. Remove the elements and separate them. Carefully check both elements for holes or tears and replace if damaged.

(2). Foam element: Clean in warm soapy water, rinse and allow to dry thoroughly. Or clean in high flash-point solvent and allow drying. Dip the element in clean engine oil and allow to dry. The engine will smoke during initial start-up if too much oil is left in the foam.

(3). Paper element: Tap the element lightly several times on a hard surface to remove excess dirt, or blow compressed air through the filter from the inside out. Never try to brush the dirt off; brushing will force dirt into the fibers.

(1) PAPER ELEMENT

(2) FOAM ELEMENT

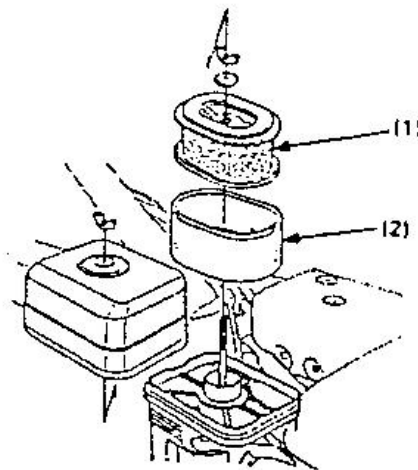

3). Fuel strainer cap cleaning

⚠ WARNING Gasoline is highly flammable and explosive under certain conditions. Do not smoke or allow flames or sparks in the area.

Turn the fuel valve to the OFF position and remove the fuel strainer cup and the O-ring. Wash the removed parts in solvent, dry them thoroughly and reinstall securely. Turn the fuel valve ON and check for leaks.

(1) O-RING

(2) FUEL STRAINER CUP

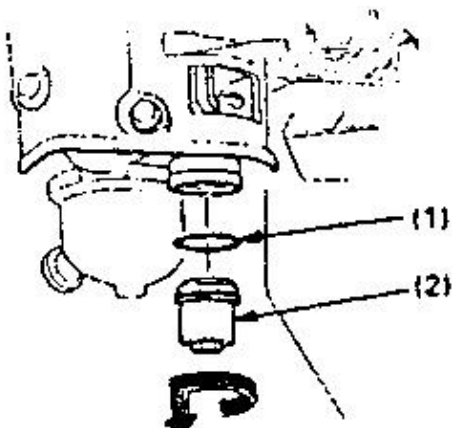

4). Spark plug service

Recommended spark plug: BPR5ES (NGK), W16EPR-U (NIPPONDENSO)

To ensure proper engine operation the spark plug must be properly gapped and free of deposits.

- Remove the spark plug cap.

⚠ WARNING

If the engine has been running the muffler will be very hot. Be careful not to touch the muffler.

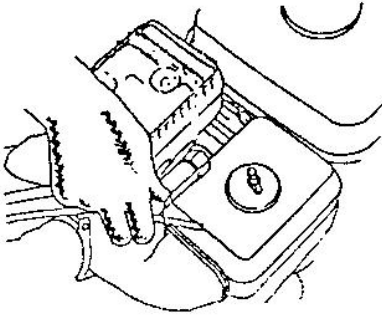

- Visually inspect the spark plug. Discard it if the insulator is cracked chipped.
- Measure the plug gap with a feeler gauge. The gap should be 0.7-0.8mm (0.028-0.031in). Correct as necessary by bending the side electrode.

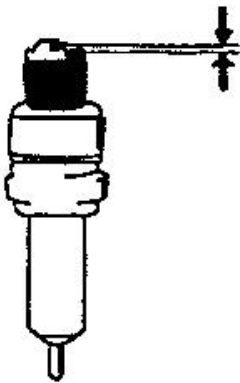

- Attach the plug washer. Thread the plug in by hand to prevent cross-threading.

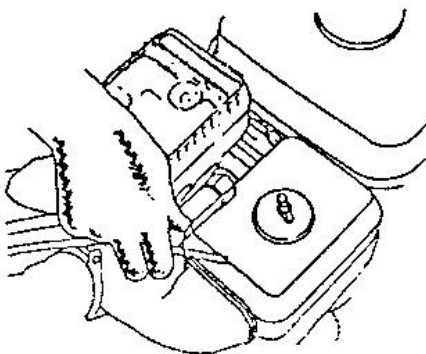

- When mounting a new spark plug, you should screw 1/2 more thread with the wrench after the washer is compressed. If you are mounting an old one, you should only screw 1/8 – 1/4 more thread.

CAUTION:

The spark plug must be securely tightened. An improperly tightened plug can become very hot and possibly damage the engine. Never use a spark plug with an improper heat range.

5). Clutch cable adjustment

Measure the free play at the lever tip

Free play: 3-8mm (0.1-0.3in)

If the free play is incorrect, loosen the lock nut and turn the adjusting bolt in or out as required.

- (1) LOCK NUT
- (2) ADJUSTING BOLT

After adjustment tighten the lock nut securely. Then start the engine and check for proper clutch lever operation.

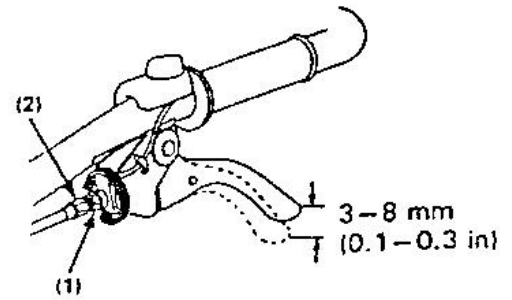

6). Throttle cable adjustment

Measure the free play at the lever tip

Free play: 5-10 mm (0.2-0.4in)

If the free play is incorrect, loosen the lock nut and turn the adjusting nut in or out as required.

- (1) THROTTLE LEVER
- (2) ADJUSTING NUT
- (3) LOCK NUT

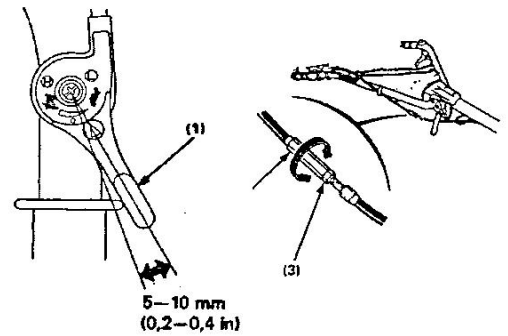

7). Belt tension adjustment

Adjust the clutch lever free play

The standard belt tension is 60-65mm (2.4-2.6 in) at the tension roller with the clutch engaged (clutch lever is squeezed).

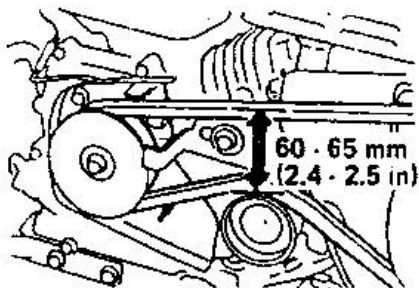

To adjust, loosen the four engine mounting bolts and the engine stay tightening bolt and move the engine forward or reverse to get proper tension of the belt.

NOTE: After adjusting the tension make sure that the outside face of the drive pulley is flush with the outside face of the driven pulley by using a straight gauge.

- (1) ENGINE MOUNTING BOLTS
- (2) ENGINE STAY TIGHTENING BOLE

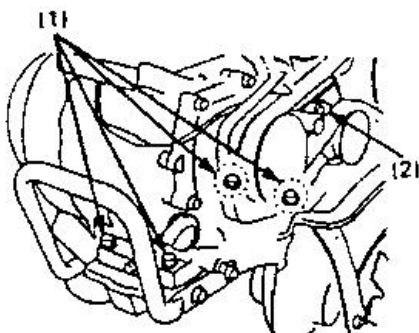

Loosen the attaching bolts of the belt stopper

Adjust the clearance between the belt stopper and the belt as illustrated with the clutch lever squeezed.

(1) BELT STOPPERS.

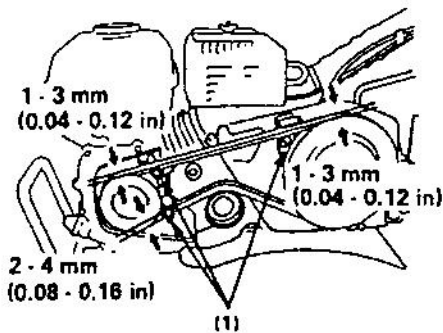

10. TRANSPORTING / STORAGE

⚠ WARNING When transporting the motor hoes, turn the fuel valve OFF and keep the motor hoes level to prevent fuel spillage. Fuel vapor or spilled fuel may be ignited.

Before storing the unit for an extended period:

- 1). Be sure the storage area is free of excessive humidity and dust.
- 2). Drain the fuel.

⚠ WARNING Gasoline is highly flammable and explosive under certain conditions. Do not smoke or allow flames or sparks in the area.

- a. With the fuel valve turned OFF, remove and empty the fuel strainer cup.
- b. Turn the fuel valve ON and drain the gasoline in the fuel tank into a suitable container.
- c. Replace the fuel strainer cup and tighten securely.
- d. Drain the carburetor by loosening the drain knob Drain the gasoline into a suitable container.

(1) O-RING

(2) FUEL STRAINER CUP

(3) DRAIN KNOB

- 3). Pull the starter grip until resistance is felt. Continue pulling until the notch on the starter puller aligns with the hole on the recoil starter

At this point, the intake and exhaust valves are closed and this will help to protect the engine from internal corrosion.

- (1) Align the notch on the starter pulley with the hole at the top of recoil starter.

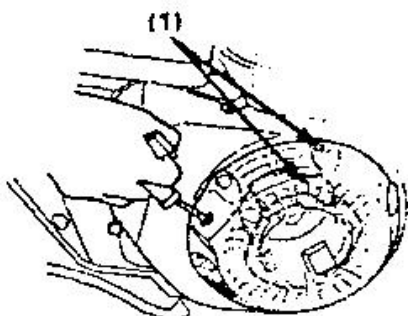
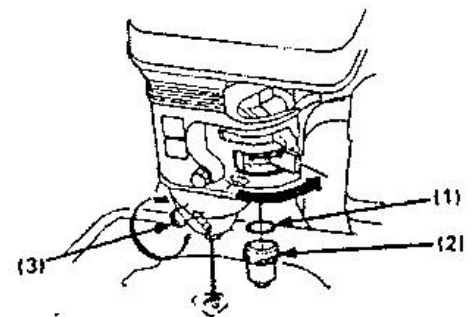

- 4). Change engine oil.
- 5). Cover tiller with plastic sheet.

Do not place the tiller with the handlebars on the ground. It will cause the oil entering the cylinder or the fuel spillage.

11. TROUBLESHOOTING

When the engine will not start:

- 1). Is there enough fuel?
- 2). Is the fuel valve on?
- 3). Is the engine switch ON?
- 4). Is gasoline reaching the carburetor?

To check, loosen the drain knob with the fuel valve ON. Fuel should flow freely. Retighten drain knob.

⚠ WARNING If any fuel is spilled, make sure the area is dry before testing the spark plug or starting the engine. Fuel vapor or spilled fuel may ignite.

- (1) FUEL VALVE
- (2) ON
- (3) DRAIN KNOB

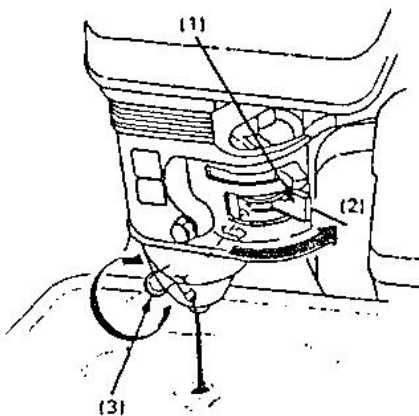

- 5). Is there a spark at the spark plug?
 - a. Remove the spark plug cap. Clean any dirt from around the spark plug base, and then remove the spark plug.
 - b. Install the spark plug in the plug cap.
 - c. Turn the engine switch on.
 - d. Grounding the side electrode to any engine ground, pull the recoil starter to see if sparks jump across the gap.
 - e. If there is not spark, replace the plug.

If OK, try to start the engine according to the instructions.

If the engine still does not start, take the tiller to an authorized Motor Hoes dealer.

12. DECLARATION OF CONFORMITY



BUILDER SAS

ZI, 32 rue Aristide Bergès – 31270 Cugnaux - France

Declares that the machinery designated below:

PETROL TILLER

HMTC100-A

Serial number: 20230602346-20230602570

Complies with the provisions of the Directive "machinery" 2006/42 / EC and the national regulations transposing it;

Also complies with the following European directives:

Emission Directive (EU) 2016/1628 and 2018/989/EU

Directive EMC 2014/30 /EU

Also complies with European standards, national standards and technical provisions following

EN 709:1997+A4:2009

EN ISO14982:2009

Cugnaux, le 21/04/2023

A handwritten signature in black ink, appearing to read 'Philippe MARIE'.

Philippe MARIE / PDG

13. WARRANTY

HYUNDAI

WARRANTY

The manufacturer guarantees the product against defects in material and workmanship for a period of 2 years from the date of the original purchase. The warranty only applies if the product is for household use. The warranty does not cover breakdowns due to normal wear and tear.

The manufacturer agrees to replace parts identified as defective by the designated distributor. The manufacturer does not accept responsibility for the replacement of the machine, in whole or in part, and/or ensuing damage.

The warranty does not cover breakdowns due to:

- insufficient maintenance.
- abnormal assembly, adjustment or operations of the product.
- parts subject to normal wear and tear.

The warranty does not extend to:

- shipping and packaging costs.
- using the tool for a purpose other than that for which it was designed.
- the use and maintenance of the machine done in a manner not described in the user manual.

Due to our policy of continuous product improvement, we reserve the right to alter or change specifications without notice. Consequently, the product may be different from the information contained therein, but a modification will be undertaken without notice if it is recognized as an improvement of the preceding characteristic.

READ THE MANUAL CAREFULLY BEFORE USING THE MACHINE.

When ordering spare parts, please indicate the part number or code, you can find this in the spare parts list in this manual. Keep the purchase receipt; without it, the warranty is invalid. To help you with your product, we invite you to contact us by phone or via our website:

- **+33 (0)9.70.75.30.30**
- **<https://services.swap-europe.com/contact>**

You must create a "ticket" via the web platform.

- Register or create your account.
- Indicate the reference of the tool.
- Choose the subject of your request.
- Describe your problem.
- Attach these files: invoice or sales receipt, photo of the identification plate (serial number), photo of the part you need (for example: pins on the transformer plug which are broken).



14. PRODUCT FAILURE

WHAT TO DO IF MY MACHINE BREAKS DOWN?

If you bought your product in a store:

- a) Empty the fuel tank if your product has one.
- b) Make sure that your machine is complete with all accessories supplied, and clean! If this is not the case, the repairer will refuse the machine.

Go to the store with the complete machine and with the receipt or invoice.

If you bought your product on a website:

- a) Empty the fuel tank if your product has one..
- b) Make sure that your machine is complete with all accessories supplied, and clean! If this is not the case, the repairer will refuse the machine.
- c) Create a SWAP-Europe service ticket on the site: <https://services.swap-europe.com> When making the request on SWAP-Europe, you must attach the invoice and the photo of the nameplate (serial number).
- d) Contact the repair station to make sure it is available before dropping off the machine.

Go to the repair station with the complete machine packed, accompanied by the purchase invoice and the station support sheet downloadable after the service request is completed on the SWAP-Europe site

For machines with engine failure from manufacturers BRIGGS & STRATTON, HONDA and RATO, please refer to the following instructions.

Repairs will be done by approved engine manufacturers of these manufacturers, see their site:

- <http://www.briggsandstratton.com/eu/fr>
- <http://www.honda-engines-eu.com/fr/service-network-page;jsessionid=5EE8456CF39CD572AA2AEEDFD290CDAE>
- <https://www.rato-europe.com/it/service-network>

Please keep your original packaging to allow for after-sales service returns or pack your machine with a similar cardboard box of the same dimensions.

For any question concerning our after-sales service you can make a request on our website <https://services.swap-europe.com>

Our hotline remains available at +33 (9) 70 75 30 30.



15. WARRANTY EXCLUSIONS

THE WARRANTY DOES NOT COVER:

- Start-up and setting up of the product.
- Damage resulting from normal wear and tear of the product.
- Damage resulting from improper use of the product.
- Damage resulting from assembly or start-up not in accordance with the user manual.
- Breakdowns related to carburetion beyond 90 days and fouling of carburetors.
- Periodic and standard maintenance events.
- Actions of modification and dismantling that directly void the warranty.
- Products whose original authentication marking (brand, serial number) has been degraded, altered or withdrawn.
- Replacement of consumables.
- The use of non-original parts.
- Breakage of parts following impacts or projections.
- Accessories breakdowns.
- Defects and their consequences linked to any external cause.
- Loss of components and loss due to insufficient screwing.
- Cutting components and any damage related to the loosening of parts.
- Overload or overheating.
- Poor power supply quality: faulty voltage, voltage error, etc.
- Damages resulting from the deprivation of enjoyment of the product during the time necessary for repairs and more generally the costs related to the immobilization of the product.
- The costs of a second opinion established by a third party following an estimate by a SWAP-Europe repair station
- The use of a product which would show a defect or a breakage which was not the subject of an immediate report and/or repair with the services of SWAP-Europe.
- Deterioration linked to transport and storage*.
- Launchers beyond 90 days.
- Oil, petrol, grease.
- Damages related to the use of non-compliant fuels or lubricants.

* In accordance with transport legislation, damage related to transport must be declared to carriers within 48 hours maximum after observation by registered letter with acknowledgement of receipt.

This document is a supplement to your notice, a non-exhaustive list.

Attention: all orders must be checked in the presence of the delivery person. In case of refusal by the delivery person, it you must simply refuse the delivery and notify your refusal.

Reminder: the reserves do not exclude the notification by registered letter with acknowledgement within 72 hours.

Information: Thermal devices must be wintered each season (service available on the SWAP-Europe site). Batteries must be charged before being stored.

HYUNDAI
POWER PRODUCTS



GENUINE PRODUCT OF
HYUNDAI CORPORATION

Pour toute demande, contactez-nous:

BUILDER SAS

32 rue Aristide Bergès - Z.I. du Casque - 31270 Cugnaux - France

Tél.: +33(0)5.34.502.502 Fax.: +33(0)5.34.502.503

<http://www.hyundaipower-fr.com/>

Fabriqu  en R publique Populaire de Chine(PRC)

Import e par BUILDER SAS, France

Licensed by Hyundai Corporation Holdings, Korea